

ARMOR DOOR

STEEL SECURITY DOORS *STRONG-SECURE-RELIABLE*



The Dynaco Armor Door is the ultimate low maintenance, high performance security door solution. Designed for demanding applications where reliability is paramount, the energy efficient Armor Door provides decades of trouble free operation in virtually any environment. Unique telescoping action utilizes minimal moving parts, is easy to repair and helps prevent transfer of contamination.

FEATURES:

Ultra Reliable Operation:
Simple design eliminates the need for counterbalance systems, hinges and pivot points. No tension on components when door is in closed position.

Strong, Secure Construction:
Inverted steel panels and locking bottom beam provide unmatched security and performance.

Extreme Environment Dependability:
Perfect for extreme weather and wind pressure applications to 50lbft². Approved for use in Florida hurricane zones.

Easy to Repair:
Damaged panels can be individually removed and repaired or replaced with minimal downtime.

Positive Locking:
Bolt type locking device automatically engages both side frames when closed.

Sound Reduction:
STC rating of 29.

Energy Saving:
Double wall construction provides an excellent U-Value of 0.51

Superior Seal:
ASTM E-283 leakage tests show 0.93cfm/lin.ft of perimeter and no air leakage through the curtain at 25 mph.



DYNACO. THE SAFEST CHOICE

ARMOR DOOR

STEEL SECURITY DOORS



Applications:

Dynaco's telescoping Armor Doors are designed to provide exceptional security, reliability and efficiency for interior or exterior applications to 800 ft². The doors are well suited for a variety of applications including Industrial, Mining, Government, Mass Transit, Institutional, Parking Structures, Aerospace etc.

Thousands installed world wide:

Armor Door is the world leader in telescoping technology with over 30 years of experience.

Attractive design:

All operating mechanisms are neatly housed within the assembly, resulting in a finished, uncluttered look. Baked on acrylic finish is available in standard and custom colors. Optional Stainless Steel panels available.

Optional high speed and UL rated fire door models:

Higher operating speeds are available. UL Class B Rated doors are available to 112 ft². Larger doors are available with an Underwriters Certificate.

Space saving profile:

The compact unit requires little head space and side clearance. The enclosed in-header drive system mounts neatly above the curtain and has minimal projection.

Smooth, reliable operation:

Inverted U-shape curtain panels glide together as the door operates. Teflon® strips separate the wear surfaces and provide quiet, weather-tight operation.

Eliminates Cross Contamination:

Unique telescoping action helps keeps dirt and contamination from transferring from one side of the door to the other.

User Friendly Controls:

State of the art DYNALOGIX controller is easy to use and self diagnostic. A view window in the NEMA 4 enclosure lets you read door status on the multi character LCD screen.

Warranty:

Dynaco backs the Armor Series with the best warranty in the industry. Five years or one million cycles on the drive motor and mechanical components. One year on electrical components.

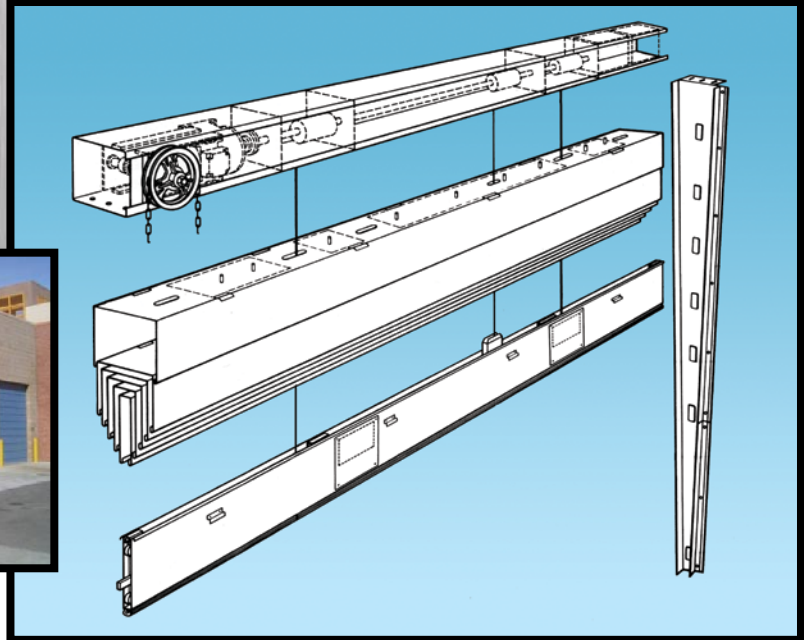
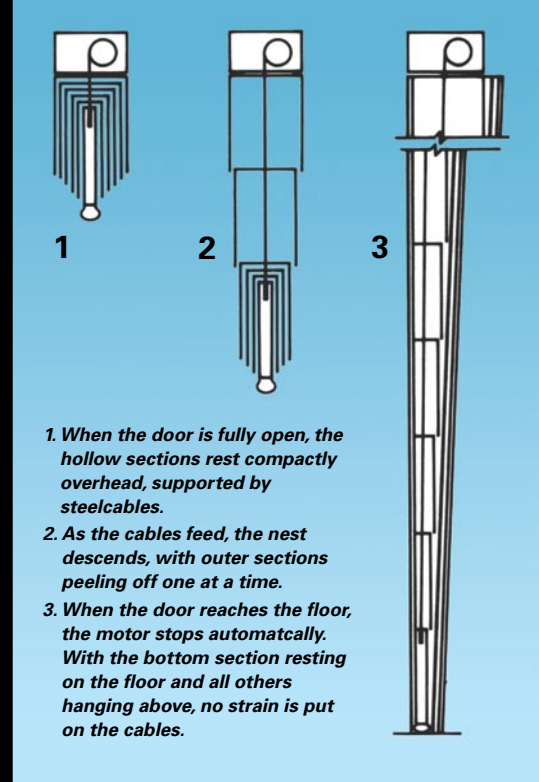

Armor Door by Dynaco was formerly known as Teledoor, Milcor and Inryco



DYNACO. THE SAFEST CHOICE

Call DYNACO for additional information • P: 1-800-459-1930 • F: 1-800-459-1960 • Email: dynaco@dynacodoor.us • www.dynacodoor.us